

ABRAXIS® Histamine ELISA Plate 515168

1. Addition of Calibrators, Samples

Add 50 μ l of the calibrator solutions, negative control, or samples to the wells of the test strips according to the working scheme given. We recommend using duplicates or triplicates.

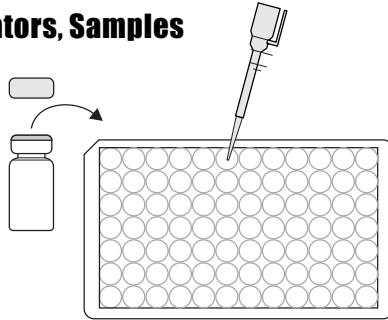

2. Addition of Conjugate Solution

Add 100 μ l of the enzyme conjugate to the individual wells successively using a multi-channel pipette or a stepping pipette. Cover the wells with parafilm or tape and mix the contents by moving the strip holder in a rapid circular motion on the benchtop. Be careful not to spill contents. Incubate the strips for 40 min at room temperature.

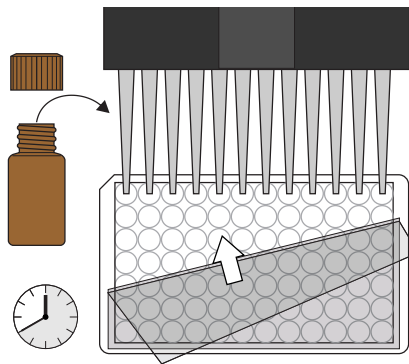

4. Addition of Substrate/Color Solution

Add 100 μ l of substrate/color solution to the individual wells successively using a multi-channel pipette or a stepping pipette. Cover the wells with parafilm or tape and mix the contents by moving the strip holder in a rapid circular motion on the benchtop. Be careful not to spill contents. Incubate the strips for 20 min at room temperature.

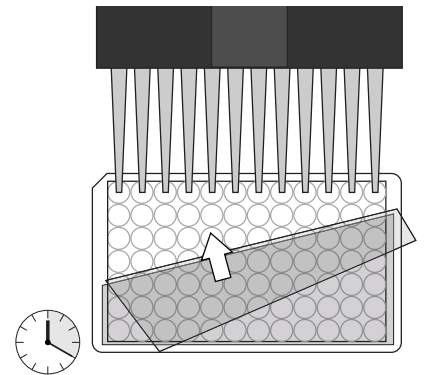

5. Addition of Stopping Solution

Add 50 μ l of stop solution to the wells in the same sequence as for the substrate solution using a multi-channel pipette or a stepping pipette.

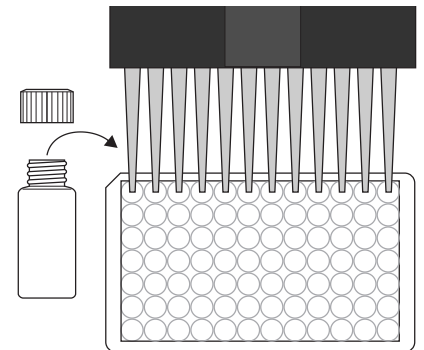

3. Washing of Plates

After incubation, remove the covering and vigorously shake the contents of the wells into a sink. Wash the strips three times with a multi-channel pipette or wash bottle using the diluted 1X washing buffer solution. Please use at least a volume of 250 μ l of washing buffer for each well and each washing step. Remaining buffer in the wells should be removed by patting the plate dry on a stack of paper towels.

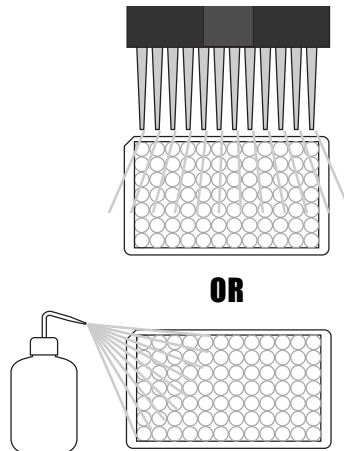

6. Measurement of Color

Read the absorbance at 405 nm using a microplate ELISA reader. Calculate results.

