

1. Derivatization Reagent Preparation

Dilute the derivatization reagent by adding 3.5 mL of the Derivatization Reagent Diluent (clear screw top glass vial) to the derivatization reagent vial (clear crimp top glass vial). Vortex and set aside.

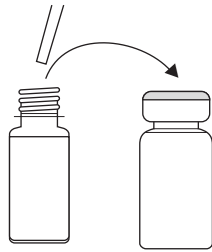

4. Addition of Derivatization Reagent

Add 100 uL of the diluted derivatization reagent (prepared in step 1) to each standard, control, and sample successively using a micropipette. Vortex each tube immediately after the addition of derivatization reagent for 15-30 seconds. Incubate tubes at room temperature for 10 minutes.

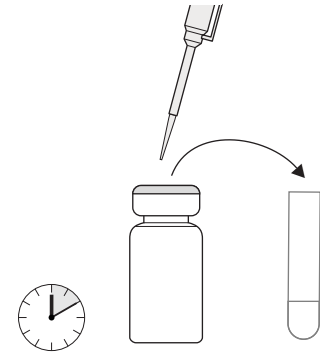

2. Addition of Sample to Test Tubes

Add 250 uL of each standard, control, and sample to the appropriate labeled glass test tube.

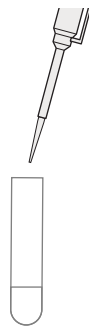

5. Analysis by ELISA

The derivatized standards, control, and samples can then be analyzed using the Glyphosate Plate or Tube ELISA Kits.

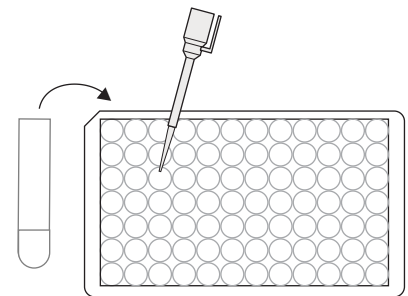

OR

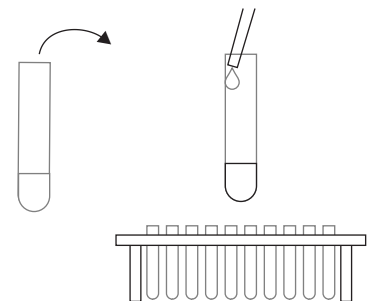

3. Addition of Buffer

Add 1 mL of Glyphosate assay buffer to each tube. Vortex each tube for approximately 1-2 seconds.

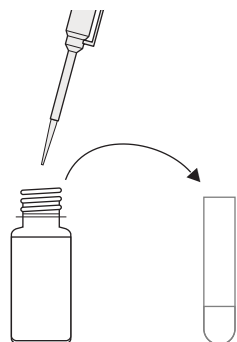

ABRAXIS® Glyphosate ELISA Plate 500205/500089

1. Addition of Standards, Samples

Add 50 uL of the derivatized standard solutions, control, or samples into the wells of the test strips according to the working scheme given. We recommend using duplicates or triplicates.

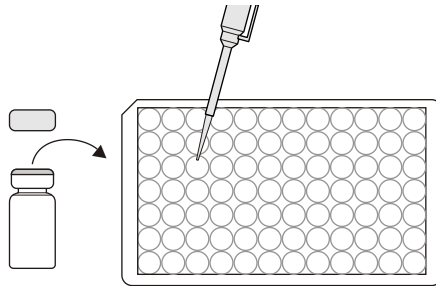

2. Addition of Antibody Solution

Add 50 uL of the anti-Glyphosate Antibody Solution into the wells of the test strips according to the working scheme given. We recommend using duplicates or triplicates. Cover the wells with parafilm or tape and mix the contents by moving the strip holder in a rapid circular motion on the benchtop for 30 seconds. Incubate for 30 minutes.

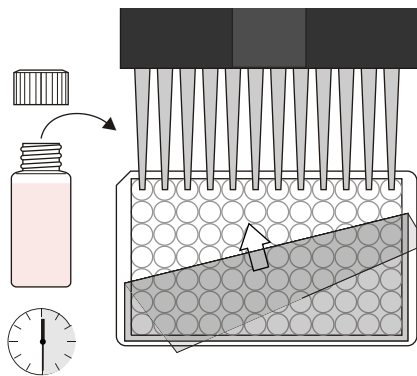

3. Addition of Enzyme Conjugate

Add 50 uL of the enzyme conjugate to the individual wells successively using a multi-channel pipette or a stepping pipette. Cover the wells with parafilm or tape and mix the contents by moving the strip holder in a rapid circular motion on the benchtop for 30 seconds. Be careful not to spill contents. Incubate for 60 minutes at room temperature.

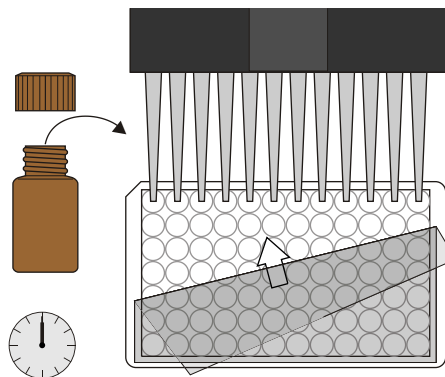

4. Washing of Plates

After incubation, remove the covering and vigorously shake the contents of the wells into a sink. Wash the strips three times with a multi-channel pipette or wash bottle using the 1X washing buffer solution. Please use at least a volume of 250 uL of washing buffer for each well and each washing step. Remaining buffer in the wells should be removed by patting the plate dry on a stack of paper towels.

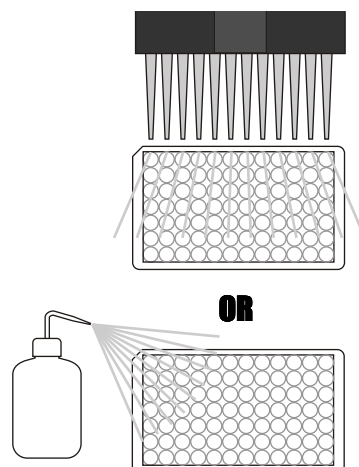

5. Addition of Substrate/Color Solution

Add 150 uL of substrate/color solution to the individual wells successively using a multi-channel pipette or a stepping pipette. cover the wells with parafilm or tape and mix the contents by moving the strip holder in a rapid circular motion on the benchtop. Be careful not to spill contents. Incubate the strips for 20-30 minutes at room temperature.

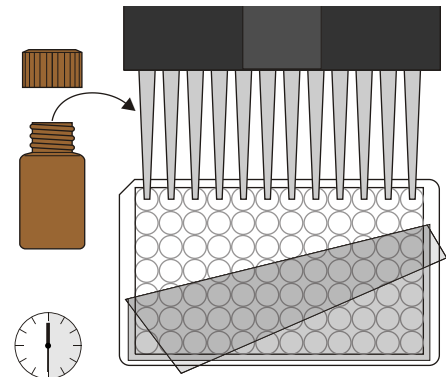

6. Addition of Stopping Solution

Add 100 uL of stop solution to the wells in the same sequence as for the substrate solution using a multi-channel pipette or a stepping pipette.

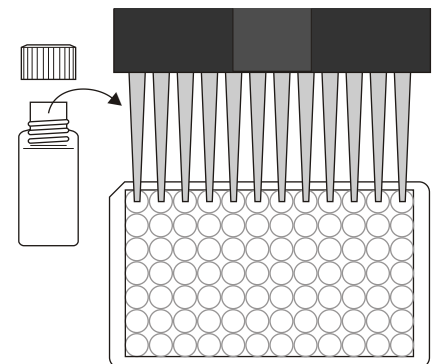

7. Measurement of Color

Read the absorbance at 450nm using a microplate ELISA reader. Calculate the results.

